

LCA015S – 1.5t Air Operated Chain Hoist

Dimensions: hook mounted hoist

LCA015S (1.5 metric ton) in inches (mm)

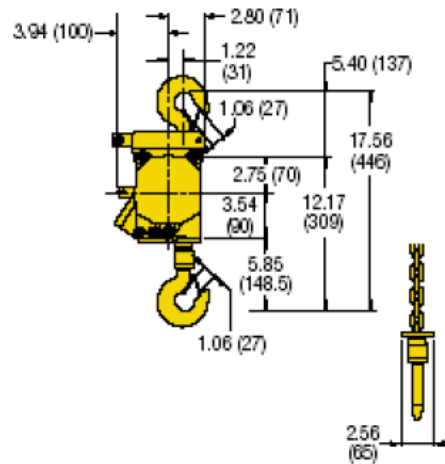

| | |
|--------------------------------|--|
| Application: | Lifting (UNDERGROUND) |
| Power Source: | Air |
| Power Supply: | 6.3 bar (90 psi) @ 2.1m ³ /min (75 cfm) |
| Capacity: | 1500kg |
| Chain Falls: | One |
| Lifting Speed (at rated load): | 4m/min |
| Lifting Speed (at no load): | 7.5m/min |
| Standard Headroom: | 446mm |
| Net Weight ⁽¹⁾ : | 50kg |
| Weight of Chain per m of lift: | 1.5kg |