

# CD220 CABLE DRUM TRAILER – 8550KG SITE TOWING ONLY

<b>Specification</b>	
Unladen Weight:	2100kgs.
Gross Weight:	10650kgs.
Nose Load:	650kgs.
Axle Load:	5000kgs.
Payload:	8550kgs.
O/all Width:	2550mm.
Max reel dia:	3660mm.
Min reel dia:	2550mm.
Max reel width:	1730mm. (with collars)
Spindle Dia:	101mm.
Tyres & Wheels:	235/75 R17.5 on 6.75 Rim
Drawbar:	660mm 76mm Eye.
Brakes:	325 x 80 2 Line air/hyd c/w ABS system
Lights:	To EEC directives.
Construction:	All steel welded
Drum lift:	Hand pump operation c/w flow balance valve, locked mechanically in raised position.
Paint:	Full gloss.

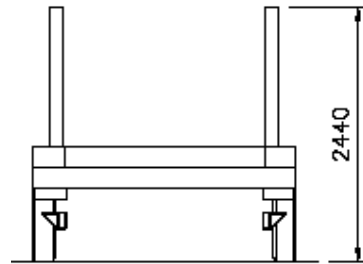
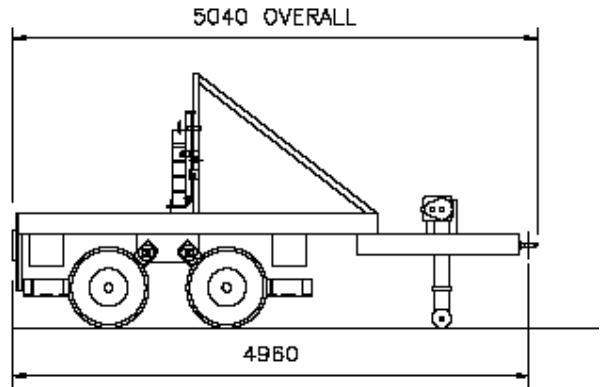

The trailer has been designed primarily for the purpose of transporting and unreeling of cable drum upto 8550kg on the highway.

The trailer rides on four pneumatic road wheels with heavy duty hollow rubber suspension units. The position of the axle stubs is such that a nose weight is always present though the drawbar in laden and unladen conditions.

Loading of the cable drum is achieved by locating the drum and spindle tube in the sliding lift chevrons which can be locked in position, twin hydraulic cylinders are then raised which leaves the drum free to unreel or be transported

