

THIRD ANGLE

DO NOT SCALE

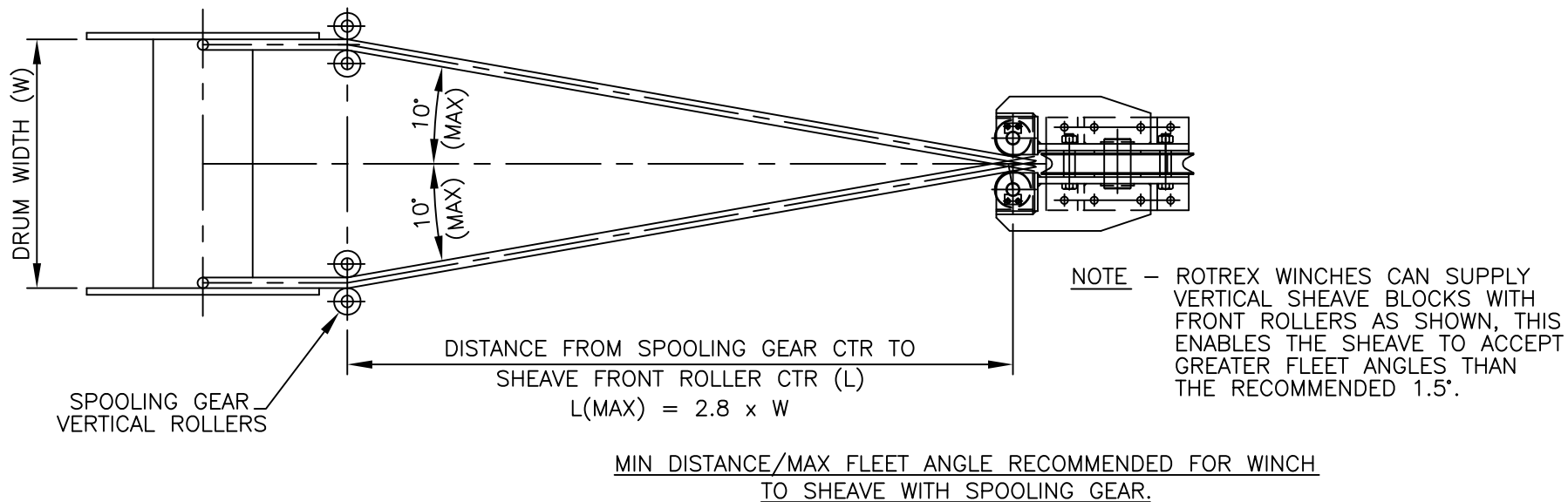
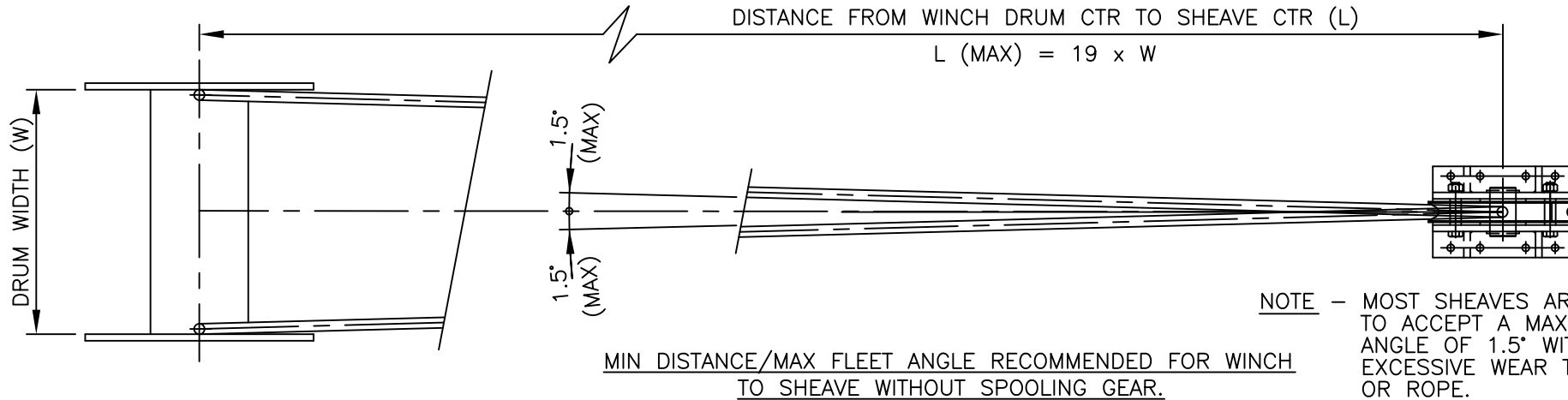

TITLE MAX RECOMMENDED ROPE FLEETING ANGLES FOR WINCHES WITH OR WITHOUT SPOOLING GEAR.

Rotrex Winches
 Website: www.rotrex.co.uk

ABERDEEN Tel: (01224) 771818
 DERBYSHIRE Tel: (01773) 603997
 MOTHERWELL Tel: (01698) 744348

TOLERANCES
 NO DECIMAL PLACES $\pm 3.0MM$
 ONE DECIMAL PLACE $\pm 0.5MM$

ROUGH M/C $\pm 0.25MM$
 FINISH M/C $\pm 0.025MM$
 OR AS STATED

GRIND TO LIMIT STATED

DRAWN
 C.R.

SCALE
 NTS

JOB No

C.N.NUMBER	REV.	AUTH
------------	------	------

TITLE

CHECKED
 C.R.

DATE
 4/09

DRG.No C7247